

AMPW CONDENSING WATER HEATERS - SUBMITTAL DATA SHEET

RATINGS AND CAPACITIES	
Input - Low Fire	800,000 BTU/HR
Input - High Fire	4,000,000 BTU/HR
Output - High Fire	3,920,000 BTU/HR
DHW Recovery (40°F to 140° Rise)...	4,704 GPH
Thermal Efficiency	98.0%
Heating Surface	402.9 Sq.Ft.
Water Content	45.3 Gallons
Fuel	Natural Gas or LP Gas
Firing Rate	Full Modulation
Burner Turndown	5:1
Low NOx Emissions	< 10 ppm
Inlet Gas Pressure (NG)	4" wc Min.
Inlet Gas Pressure (LP)	8" wc Min.
	14" wc Max.
Shipping Weight, Approximate	2,485 lbs

ASME Section IV (Max 160 PSIG / 210°F)	
ETL Certified to ANSI Z21.13 / CSA 4.9	
UL 795 / CSA 3.1	
NSF/ANSI Standard 372	

DIMENSIONS / CONNECTIONS	
- Height	55" (Note 1)
- Width	44" (Note 2)
- Length	92" (Note 3)
- Supply Connection	4" Grooved
- Return Connection	4" Grooved
- Vent / Air Intake Connections	12"
- Gas Connection	2" NPT

STANDARD EQUIPMENT	
- ASME Stainless Steel Heat Exchanger	
- Stainless Steel Pre-Mix Burner	
- Variable Speed Combustion Blower	
- Concert Control™ (24v)	
- High Limit Temperature Control, Manual Reset	
- Water Flow Switch	
- Low Water Cutoff, Manual Reset	
- Condensate Trap	
- Blocked Condensate Switch	
- ASME Temperature & Pressure Relief Valve	
- Temperature & Pressure Gauge	
- Supply, Return & DHW Temperature Sensors	
- Flue Gas Temperature Sensor	
- Air Vent Valve	
- Modulating Gas Valve	
- Direct Spark Ignition and UV Scanner	
- High/Low Gas Pressure Switches, Manual Reset	
- Combustion Air Switch	
- Blocked Vent Switch	
- 208-240-460v/3ph/60hz Line Voltage	
- Amp Draw: 208v (11.0); 240v (9.9) and 460v (6.4)	
- Category II and IV Venting	
- Individual or Common (Engineered) Vent System	
- CPVC, Polypropylene & Stainless Steel Acceptable *Material	
- Sealed or Room Combustion Air Intake	
- Up to 300 ft equivalent venting / air intake	

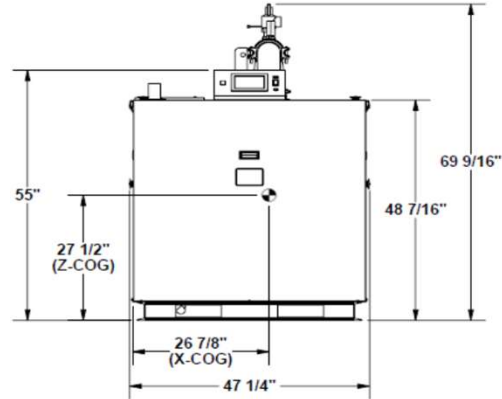

Front View

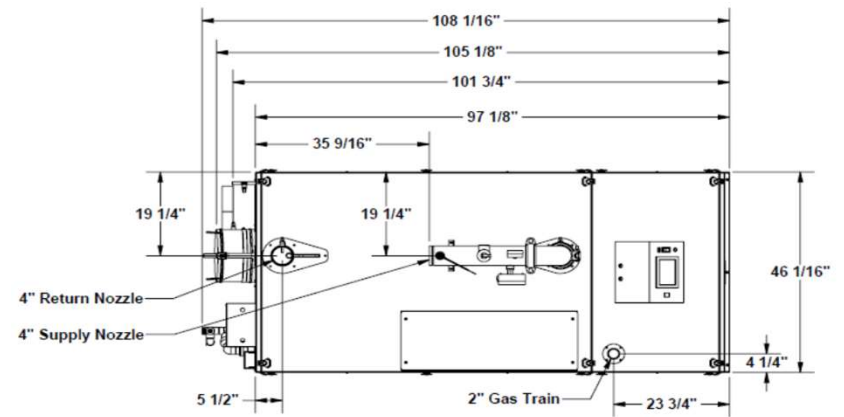

Top View

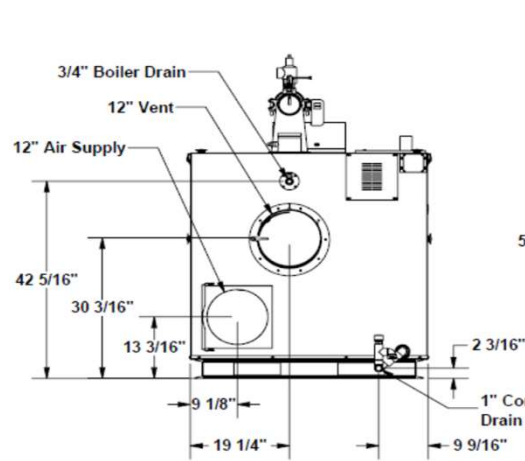

Rear View

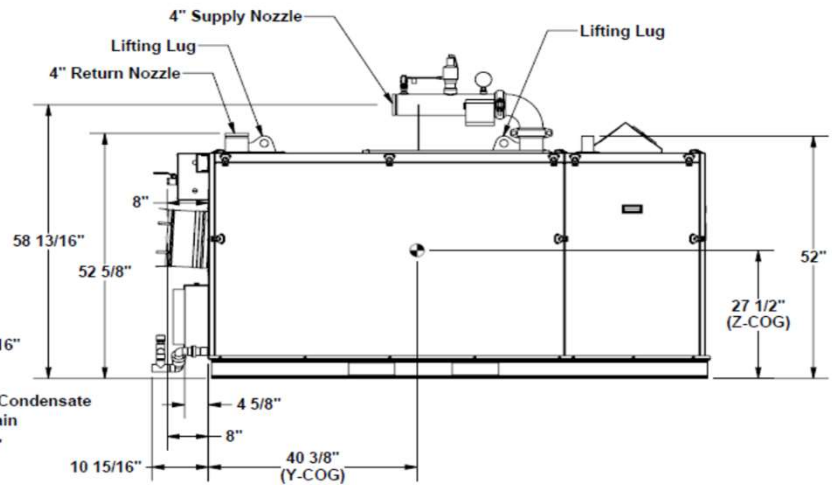

Left Side View

- NOTES:
1. Height dimension is from floor to top of control box.
 2. Width does not include jacket butterfly clips that require 3/4" +/- clearance on each side.
 3. Length is from jacket front to jacket rear.
 4. Dimensions shown are for reference only

FLOW REQUIREMENTS		
Water Hardness	Flow (GPM)	r P (Fl. Hd)
5 - 12 gpg	280	11.0
12 - 15 gpg	372	18.0

* Flue system material shall be capable of continuous operation at 210°F or higher and shall be certified to UL 1738 – venting system for gas-burning appliances cat II, III and IV.

AMPW-4000

PROPERTY OF
THERMAL SOLUTIONS
Innovative Equipment for Hot Water Systems

PO BOX 3244 | LANCASTER, PA. 17601

INNOVATIVE EQUIPMENT FOR
HOT WATER SYSTEMS

WWW.THERMALSOLUTIONS.COM

Updated 1/2024